

- I** AUTOMAZIONE OLEODINAMICA INTERRATA PER CANCELLI A BATTENTE
- GB** PISTON AUTOMATIONS FOR SWING GATES
- F** AUTOMATISME OLÉODYNAMIQUE ENTERRÉ POUR PORTAILS A VANTAUX
- D** HYDRAULISCHER UNTERFLURDREHTORANTRIEB
- E** AUTOMATISMO OLEODINÁMICO SOTERRADO PARA PORTONES BATIENTES
- P** AUTOMAÇÃO ÓLEODINÂMICA ENTERRADA PARA PORTÕES DE BATENTE

**SUB**

**ISTRUZIONI D'USO E DI INSTALLAZIONE**  
**INSTALLATION AND USER'S MANUAL**  
**INSTRUCTIONS D'UTILISATION ET D'INSTALLATION**  
**MONTAGE- und BEDIENUNGSANLEITUNG**  
**INSTRUCCIONES DE USO Y DE INSTALACION**  
**INSTRUÇÕES DE USO E DE INSTALAÇÃO**

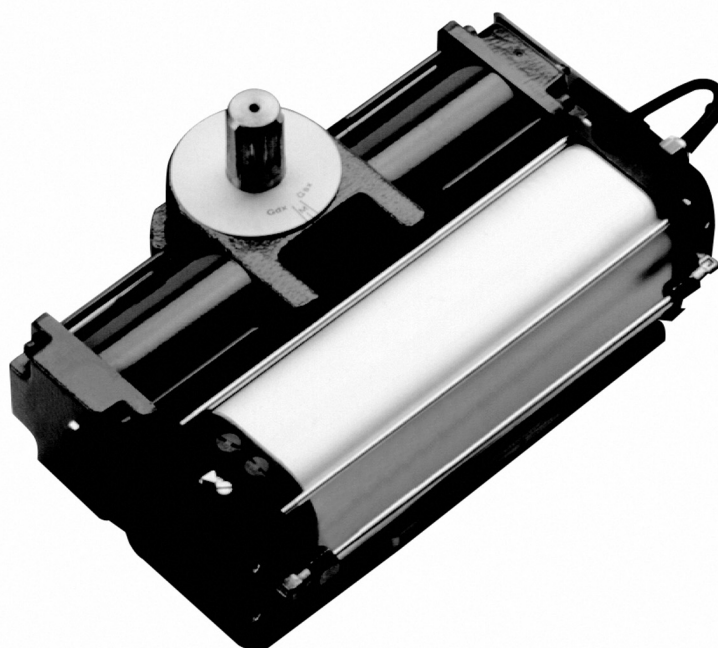

**AZIENDA CON SISTEMA QUALITÀ**  
**CERTIFICATO DA DNV**  
**UNI EN ISO 9001**

Via Lago di Vico, 44  
 36015 Schio (VI)  
 Tel.naz. 0445 696511  
 Tel.int. +39 0445 696533  
 Fax 0445 696522  
 Internet: [www.bft.it](http://www.bft.it)  
 E-mail: [sales@bft.it](mailto:sales@bft.it)





**DICHIARAZIONE DI CONFORMITÀ / DECLARATION OF CONFORMITY / DÉCLARATION DE CONFORMITÉ  
KONFORMITÄT SERKLÄRUNG / DECLARACION DE CONFORMIDAD / DECLARAÇÃO DE CONFORMIDADE**

Fabbricante / Manufacturer / Fabricant / Hersteller / Fabricante / Fabricante:

BFT s.r.l.

Indirizzo / Address / Adresse / Adresse / Dirección / Endereço:

Via Lago di Vico 44  
36015 - Schio  
VICENZA - ITALY

- Dichiara sotto la propria responsabilità che il prodotto:
- Declares under its own responsibility that the following product:
- Déclare sous sa propre responsabilité que le produit:
- Erklärt auf eigene Verantwortung, daß das Produkt
- Declara, bajo su propia responsabilidad, que el producto:
- Declara, sob a sua responsabilidade, que o produto:

|   |  |
|---|--|
| Motoriduttore per cancelli a battente mod.    | SUB,SUBE,SUBG,SUB EG,SUB GR,SUB R,SUB ER,SUB EL,SUB GER,SUB GR |
| Gearmotor for swing gates mod.                | SUB,SUBE,SUBG,SUB EG,SUB GR,SUB R,SUB ER,SUB EL,SUB GER,SUB GR |
| Motoréducteur pour portails battants mod.     | SUB,SUBE,SUBG,SUB EG,SUB GR,SUB R,SUB ER,SUB EL,SUB GER,SUB GR |
| Getriebemotor für Drehtore Modell             | SUB,SUBE,SUBG,SUB EG,SUB GR,SUB R,SUB ER,SUB EL,SUB GER,SUB GR |
| Motorreductor para cancelas con batiente mod. | SUB,SUBE,SUBG,SUB EG,SUB GR,SUB R,SUB ER,SUB EL,SUB GER,SUB GR |
| Motoredutor para portões de batente mod.      | SUB,SUBE,SUBG,SUB EG,SUB GR,SUB R,SUB ER,SUB EL,SUB GER,SUB GR |

- È costruito per essere incorporato in un macchinario che verrà identificato come macchina ai sensi della DIRETTIVA MACCHINE.
- Has been produced to be incorporated into a machinery, which will be identified as a machine according to the MACHINERY DIRECTIVE.
- A été construit pour l'incorporation successive dans un équipement qui sera identifié comme machine conformément à la DIRECTIVE MACHINES
- Dafür konstruiert wurde, in ein Gerät eingebaut zu werden, das als Maschine im Sinne der MASCHINEN-DIREKTIVE identifiziert wird.
- Ha sido construido para ser incorporado en una maquinaria, que se identificará como máquina de conformidad con la DIRECTIVA MAQUINAS.
- Foi construído para ser incorporado numa maquinaria, que será identificada como máquina em conformidade com a DIRECTIVA MÁQUINAS
- É conforme ai requisiti essenziali di sicurezza delle Direttive:
- It also complies with the main safety requirements of the following Directives:
- Est conforme aux exigences essentielles de sécurité des Directives:
- Es entspricht den grundlegenden Sicherheitsbedingungen der Direktiven:
- Es conforme a los requisitos esenciales de seguridad de las Directivas:
- Está conforme aos requisitos essenciais de segurança das Directivas:

BASSA TENSIONE  
LOW VOLTAGE  
BASSE TENSION  
NIEDERSpannung  
BAJA TENSION  
BAIXA TENSÃO

73/23/CEE, 93/68/CEE (EN 60335-1 (1995))

DIRETTIVA MACCHINE  
MACHINERY DIRECTIVE  
DIRECTIVE MACHINES  
MASCHINEN-DIREKTIV  
DIRECTIVA MAQUINAS  
DIRECTIVA MÁQUINAS

98/37/CEE

- Si dichiara inoltre che è vietata la messa in servizio del prodotto, prima che la macchina in cui sarà incorporato, sia stata dichiarata conforme alle disposizioni della DIRETTIVA MACCHINE.
- We also declare that it is forbidden to start the product before the machinery into which it will be incorporated is declared in compliance with the prescriptions of the MACHINERY DIRECTIVE.
- Nous déclarons en outre que la mise en service du produit est interdite, avant que la machine où il sera incorporé n'ait été déclarée conforme aux dispositions de la DIRECTIVE MACHINES.
- Es wird außerdem erklärt, daß die Inbetriebnahme des Produkts verboten ist, solange die Maschine, in die es eingebaut wird, nicht als mit den Vorschriften der MASCHINEN-DIREKTIVE konform erklärt wurde.
- Se declara, además, que está prohibido instalar el producto antes de que la máquina en la que se incorporará haya sido declarada conforme a las disposiciones de la DIRECTIVA MAQUINAS
- Declaramos, além disso, que é proibido instalar o produto, antes que a máquina em que será incorporada, tenha sido declarada conforme às disposições da DIRECTIVA MÁQUINAS

SCHIO

30.11.2000

Il Rappresentante Legale / The legal Representative  
Le Représentant Légal / Der gesetzliche Vertreter  
El Representante Legal / O Representante legal

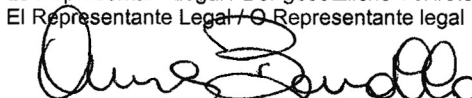

Thank you for buying this product, our company is sure that you will be more than satisfied with its performance. This product is supplied with a "WARNINGS" leaflet and an "INSTRUCTION MANUAL". These should both be read carefully as they provide important information about safety, installation, operation and maintenance. This product complies with recognised technical standards and safety regulations. We declare that this product is in conformity with the following European Directives: 73/23/EEC, 98/37 EEC and subsequent amendments.

## 1) GENERAL OUTLINE

The **SUB** hydraulic controller provides the ideal solution for underground hinge-pivot installations, as it brilliantly solves aesthetic automation problems. The **SUB** actuator consists of a perfectly sealed single block, containing a hydraulic control unit and a jack, which provides a hidden underground installation without any hydraulic connections. The gate is kept closed by an electric lock, or by a hydraulic lock on the **SUB** versions supplied with it. The versions with slow-down functions avoid unpleasant slamming noise when the gate is brought to the final opening and closing stages. The pushing force can be adjusted with extreme precision by means of two by-pass valves which provide antisquash safety. The end-of-stroke operation is electronically set by a timer on the control panel. The emergency release, activated by the proper key supplied, can be easily reached after removing the appropriate cap found on the cover.

## 2) GENERAL SAFETY

**WARNING! An incorrect installation or improper use of the product can cause damage to persons, animals or things.**

- The "Warnings" leaflet and "Instruction booklet" supplied with this product should be read carefully as they provide important information about safety, installation, use and maintenance.
- Scrap packing materials (plastic, cardboard, polystyrene etc) according to the provisions set out by current standards. Keep nylon or polystyrene bags out of children's reach.
- Keep the instructions together with the technical brochure for future reference.
- This product was exclusively designed and manufactured for the use specified in the present documentation. Any other use not specified in this documentation could damage the product and be dangerous.
- The Company declines all responsibility for any consequences resulting from improper use of the product, or use which is different from that expected and specified in the present documentation.
- Do not install the product in explosive atmosphere.
- The construction components of this product must comply with the following European Directives: 73/23/EEC, 98/37 EEC and subsequent amendments. As for all non-EEC countries, the above-mentioned standards as well as the current national standards should be respected in order to achieve a good safety level.
- The Company declines all responsibility for any consequences resulting from failure to observe Good Technical Practice when constructing closing structures (door, gates etc.), as well as from any deformation which might occur during use.
- The installation must comply with the provisions set out by the following European Directives: 73/23/EEC, 98/37 EEC and subsequent amendments.
- Disconnect the electrical power supply before carrying out any work on the installation. Also disconnect any buffer batteries, if fitted.
- Fit an omnipolar or magnetothermal switch on the mains power supply, having a contact opening distance equal to or greater than 3mm.
- Check that a differential switch with a 0.03A threshold is fitted just before the power supply mains.
- Check that earthing is carried out correctly: connect all metal parts for closure (doors, gates etc.) and all system components provided with an earth terminal.
- Fit all the safety devices (photocells, electric edges etc.) which are needed to protect the area from any danger caused by squashing, conveying and shearing.
- Position at least one luminous signal indication device (blinker) where it can be easily seen, and fix a Warning sign to the structure.
- The Company declines all responsibility with respect to the automation safety and correct operation when other manufacturers' components are used.
- Only use original parts for any maintenance or repair operation.
- Do not modify the automation components, unless explicitly authorised by the company.
- Instruct the product user about the control systems provided and the

manual opening operation in case of emergency.

- Do not allow persons or children to remain in the automation operation area.
- Keep radio control or other control devices out of children's reach, in order to avoid unintentional automation activation.
- The user must avoid any attempt to carry out work or repair on the automation system, and always request the assistance of qualified personnel.
- Anything which is not expressly provided for in the present instructions, is not allowed.

## 3) MAIN AUTOMATION PARTS

Single-block hydraulic actuator (fig.1) consisting of:

- M)** 2-pole single-phase motor protected by thermal circuit-breaker.
- P)** Hydraulic lobe pump.
- D)** Distributor with adjustment valves.
- PC)** Rack - pinion jack.

Components supplied as standard: by-pass release and adjustment key, capacitor, grooved bush and instruction manual.

**WARNING:** An actuator can be mounted on the left or right-hand side, as identified by looking at the gate from the inside (opening direction). An actuator can be recognised as left or right-handed by observing the position of release pivot "PST". Fig.1 shows an actuator to be mounted on the left.

## 4) ACCESSORIES

- **CPS** Bearing foundation case (provided for automation).
- **CID** Non-bearing foundation case.
- **BSC** Slide arm (for mounting to one side of the hinge-pivot).

## 5) TECHNICAL SPECIFICATIONS

|                                 |   |
|---------------------------------|---|
| Single-phase power supply ..... | 230V~ ±10% 50/60 Hz                     |
| Motor revolutions .....         | 2800 min <sup>-1</sup>                  |
| Output shaft revolutions .....  | See Table 1                             |
| Absorbed power .....            | 250 W                                   |
| Capacitor .....                 | 6.3 µF                                  |
| Absorbed current .....          | 1.4 A                                   |
| Max torque .....                | 400 Nm                                  |
| Pressure .....                  | 3MPa (30 bar) max                       |
| Pump capacity .....             | See Table 1                             |
| Impact reaction .....           | Hydraulic clutch                        |
| Manual manoeuvre .....          | Release key                             |
| Max no. manoeuvres .....        | 500 / 24hours                           |
| Thermal protection .....        | 160 °C                                  |
| Environmental conditions .....  | -10 °C to +60 C°                        |
| Degree of protection .....      | IP 67                                   |
| Controller weight .....         | SUB 220N (~22 kg) - SUB G 240N (~24 kg) |
| Oil .....                       | IDROLUX                                 |
| Dimensions .....                | See fig.2                               |

(\* ) Special voltages available on request.

## 6) ACTUATOR INSTALLATION

### 6.1) Preliminary checks

Check that:

- The leaf structure is sturdy and rigid.
- The upper hinge is in working order and possibly adjustable.
- A hole can be dug to lay the case under the hinge-pivot, or to one side of the hinge-pivot for slide arm installation.
- The leaf ground stop plates are fitted.
- Repair or replace all faulty or worn components.

Fig.3 illustrates an exploded view of the installation. Automation reliability and safety are directly affected by the condition of the gate structure.

### 6.2) Electrical installation setup

Set up the electrical installation as shown in fig.4, making reference to the current standards for electrical installations, i.e. CEI 64-8, IEC364, complying with HD384 and other national standards. Keep the mains supply connections definitely separate from the service connections (photocells, electric edges, control devices, etc.).

**WARNING: For connection to the mains, use a multipolar cable of the type provided for by the previously mentioned standards (for example, if the cable is not protected, it must be at least equal to H07 RN-F, whereas if it is protected it must be at least equal to H07 VV-F with a 3x1.5 mm<sup>2</sup> cross section).**

Connect the control and safety devices in compliance with the previously mentioned installation standards. Fig.4 shows the number of connections

and the cross section for power supply cables about 100-m long; for greater lengths, calculate the cross section needed for the true automation load.

### 6.3) Main automation parts (Fig.4):

- I) Type-approved adequately rated omnipolar circuit-breaker with at least 3-mm contact opening, provided with protection against overloads and short circuits, suitable for cutting out automation from the mains. If not already installed, place a type-approved omnipolar circuit-breaker with a 0.03A threshold just before the automation system.
- Qr) Control panel and incorporated receiver.
- SPL) Preheating board for operation with temperature lower than 5°C (optional).
- S) Key selector.
- AL) Blinker with tuned antenna.
- M) Controller.
- E) Electric lock.
- Fte) External photocells (emitting section).
- Fre) External photocells (receiving section).
- Fti) Internal photocells with CF posts (emitting section).
- Fri) Internal photocells with CF posts (receiving section).
- T) 1-2-4 channel transmitter.
- RG58) Cable for antenna.
- D) Connector block.



**The connector block (fig. 6) must always be positioned higher than the motor. In fact, as the controller is perfectly sealed, the tank is made to breathe through the actuator supply cable.**

### 6.4) Cementation of the foundation case (under the hinge-pivot)

The case must be cemented under the hinge-pivot, keeping in mind that the actuator bearing shaft must be perfectly aligned to the leaf rotation axis. If the gate is provided with fixed hinges, disassemble it and remove the lower hinge. If the leaf is high enough from the ground and cannot be removed, proceed to supporting it by means of a shim placed between the ground and the leaf during installation. If the gate is provided with adjustable hinges, remove the lower hinge, loosen the upper one and move the leaf to the side. If the gate has been newly manufactured, fit an upper hinge which can be adjusted.

- Dig a foundation hole having the dimensions shown in fig.5.
- Provide a drainage pipe (fig.6) for rainwater in order to prevent stagnation inside the foundation case. Lay a raceway for the power supply cable as far as connector block "D"
- Lay a strong foundation on the bottom (fig.5) where to bury the hooks of foundation case "P". The dimensions for positioning plate "P" are defined in fig.5. Let the cement harden for the time needed.
- Rest the actuator on base "P", with its shaft perfectly aligned to the leaf axis (fig.7), and weld four angle bars "A" in correspondence with the four corners of the actuator centring base. The minimum dimension between the pillar and rotation shaft axis is shown in fig.6.
- Assemble the foundation case by fixing its two half sections together by means of the screws supplied (fig.8), and fixing small plate "PI" to the back. Position the box around the actuator, so that small plate "PI" (fig.8) fits around the shaft, and the edge of the box protrudes above the ground by about 10mm (fig.6). Position cover "CE" (fig.3) on the box and fix its corners with 2 screws.
- Fill the rest of the hole with concrete.

### 6.5) Cementation of the foundation case (to one side of the hinge-pivot)

Installation with slide arm (to one side of the hinge pivot). This is advisable when you want to avoid disassembling the existing gate leaf. Area "A" highlighted in fig.9 corresponds to a right-angled triangle having a side of approximately 200mm, where the actuator axis can be laid in order to allow the leaf to open by at least 90°.

- The drive arm provides a distance between centres between grooved bush "B" and sliding roller "R" of up to 380mm.
- Bush "B" must be welded to the drive arm with the leaf completely closed, the roller must be inserted into slide "S" taking into account the safety degrees shown on small card "CA" (fig.11). For slowed-down versions, also take into account the slow-down degrees (fig.13).
- Slide "S" (fig.9) can be welded or fixed with screws both underneath and to the side of the leaf. The position of the slide is to be identified by marking on the leaf the spots reached by sliding roller "R" both during closing and opening. Having identified the mid-point between the two markings made previously, align the mid-point of slide "S" and fix it tightly. If slide "S" is shorter than the distance between the two markings on the leaf, this type of installation is not possible. Keep in mind that, the

nearer slide "S" is to the leaf rotation pivot, the greater will be the leaf speed. Having identified the actuator position, proceed to cementing the foundation case as described in paragraph 6.4.

### 7) BEARING FOUNDATION CASE

Two bearing foundation case models - CPS for SUB and CPS G for SUB G (fig.10) - are available. Having installed the bearing case, the gate becomes operational even without mounting the actuator, which can be inserted later. In case of any maintenance needed, this type of case allows the actuator to be removed without disassembling the gate leaf. Should the CPS mod. bearing foundation case be used, refer to the respective manual for the positioning procedure.

### 8) LEAF MOUNTING

With the actuator in its final position, proceed as follows.

- Prepare a U-shaped shoe (fig.3) where the leaf is to be inserted and then fastened in its correct position by welding small plate "PS" to it.
  - Position grooved bush "B" in the actuator shaft.
  - Temporarily fasten the shoe to the leaf: mount the leaf in its completely closed position, placed over the actuator shaft and perfectly aligned to the rotation axis.
  - Before welding bush "B" to the U-shaped shoe, the right fixing point must be found. To determine the correct point, proceed as described below.
- WARNING:** Do not weld bush "B" directly to the leaf. Do not weld the grooved bush to the actuator output shaft.

#### 8.1) Version without slow-down function

- Release the jack with key "CS" supplied, in the way shown in fig.18.
- With the help of pliers, completely rotate the output shaft in the direction of gate closing along its entire stroke.
- Arrange small card "CA" (fig.11) by positioning point "M" in correspondence with the arrow in the casting.
- Rotate the shaft and bring point "G" (right-r.h. or left-l.h.) in correspondence with the arrow.
- Protect the actuator from any metal spots during the subsequent welding phase.
- The bush can now be welded to the shoe with the leaf mounted in the gate closed and stopped position. Disassemble the shoe to weld bush "B" all the way around its circumference.
- Any small defects in levelling foundation plate "P" can be corrected by means of adjustment dowels "GR" (fig.3).
- Place the gate stop on opening in the required position; however, the gate stop must maintain an extra rotation of at least 5° for safety, in order to prevent the rack from reaching its end of travel.

**NOTE:** The rotation degrees of the SUB R versions are highlighted in fig.12; in the case of versions without slow-down function, consider the slow-down angles (25°+25°) as normal speed. For the SUB G versions, take into account a total rotation of 185°. For effective 180° openings, the safety margin is 2.5° both on closing and on opening.

#### 8.2) Version with slow-down function

The versions provided with slow-down function need particular attention in identifying the fixing point of grooved bush "B" (fig.3). It is advisable to use the actuator in a symmetrical way; fig.12 shows the 130 degrees of total rotation of an ordinary actuator, divided into the various phases. By way of example, fig.13 shows the correct operation method for an actuator carrying out a leaf opening manoeuvre of 90°, that is 20°+20° for safety, 70° for normal stroke and 10°+10° for slow-down. In order to obtain the angles described, use small card "CA" on the "SUB R mod." side (fig.11).

**WARNING:** For effective opening manoeuvres of less than 90°, slow-down cannot be obtained in both directions. You need to decide beforehand whether to have slow-down on closing or opening, taking into account that slow-down begins to happen in the last 25°-30° of shaft rotation, both on opening and closing (fig.14). Having determined the correct angle for fixing the grooved bush, fix it in the way described in paragraphs 8 - 8.1.

**NOTE:** For the SUB GR versions, take into account a total rotation of 185°, out of which: 2.5°+2.5° for safety, 25°+25° for slow-down and 125° for stroke at normal speed. This provides a maximum rotation of 180°.

#### 8.3) Slow-down adjustment (R versions only)

Slow-down adjustment screws "VR" are highlighted in fig.15, and can be adjusted by means of a 3-mm Allen wrench. This must be turned clockwise to make the movement slower and anticlockwise to make it less slow. Adjust the slow-down speed so as to prevent the leaf from slamming when it stops.

#### 8.4) Installation with slide arm (to one side of the hinge-pivot)

This type of installation is illustrated in fig.9. The installation method is described in paragraph 6.5. Furthermore, the actuator support base must be tightly secured to the foundation base by means of screws, and not just fastened by the four angle bars as in the case of installation under the hinge-pivot.

#### 9) STOP PLATES

The use of ground stop plates "F" (fig.20) is compulsory both on opening and closing. The stop plates must lock the leaf while maintaining a safety extra-stroke of 5° at least (fig.12).

#### 10) LEAF PHASE DIFFERENCE

In the case where the leaves overlap during the closing manoeuvre, the phase difference on closing is set by means of the appropriate trimmer included in the electronic control unit. The motor of the delayed leaf must be connected to the terminals of the control unit, which are identified by the "Mr" symbol as illustrated in the control unit wiring diagram.

#### 11) ELECTRIC LOCK FITTING

This is only needed for models without hydraulic lock on closing (Table 1). The EBP mod. electric lock (fig.16) consists of a continuous- service electromagnet hooked to the ground. This device remains energised during the whole gearmotor operation time, allowing catch "D" to reach the closing stop point without opposing any resistance; this factor allows the pushing load to be reduced on closing, thus improving antisquash safety.

#### 12) PUSHING FORCE ADJUSTMENT (Fig.1)

This is obtained by means of two valves, marked by the writing "close" and "open" respectively, used to adjust the pushing force on closing and opening. If the valves are turned towards the "+" sign the force is increased, if they are turned towards the "-" sign it is decreased. To obtain good antisquash safety, the pushing force must be slightly greater than that needed to move the leaf, both on closing and opening; however, the force, measured at the leaf edge, must not exceed the limits set out by the current national standards. The actuator is not provided with electrical limit switches. Therefore the motors are switched off at the end of the operation time set in the control unit. Such operation time must exceed by about 2-3 seconds the moment where the leaves meet the ground stop plates. For this reason as well as for safety reasons, under no circumstances must the by-pass valves be completely closed.

#### 13) MANUAL OPENING

In case of emergency, for instance when there is no power available, the gate must be opened by hand.

##### 13.1) Versions without hydraulic locks (electric lock)

As these models are irreversible, in order to move the gate by hand you only need to open the electric lock by means of the appropriate key, and push the leaves with a force strong enough to win that adjusted with the by-pass valves (approximately 15 kg/150N). In order to make the manoeuvre easier, it may also be helpful to activate the hydraulic lock in the way described below.

##### 13.2) Versions with hydraulic locks (Fig.17)

- Unscrew cap "T" which is found on the cover of each actuator (usually on the inside).
- Insert the release key supplied in triangular release pivot PST and rotate it anticlockwise by a few turns (CS in fig.18).
- Push the leaf by hand at a speed similar to that of motorised operation.
- To restore motorised operation, turn the key clockwise until it is completely tightened, screw the release cap onto the cover and put the key in a place which is known to all users.

**NOTE:** In order to avoid oxidation of the release device, it is helpful to fill its triangular seat with grease.

#### 14) AUTOMATION CHECK

Before finally making the automation fully operative, carefully carry out the following procedure:

- Check that all components are tightly secured.
- Check the correct functioning of all safety devices (photocells, pneumatic edge etc.).
- Check the emergency manoeuvre command.
- Check the opening and closing operations with the control devices in use.
- Check the standard (or customised) electronic function logic in the control unit.

#### 15) AUTOMATION OPERATION

As automation can be remotely controlled by means of a radio control or start button, it is essential to frequently check that all safety devices are perfectly efficient. In case of any operational malfunction, take immediate action and request the assistance of qualified personnel. It is recommended to keep children at a safe distance from the automation field of action.

#### 16) CONTROL

The automation system is used to obtain motorised gate opening and closing. There are different types of control (manual, radio, magnetic badge access control, etc.) depending on the installation requirements and characteristics. For the various control systems, see the relevant instructions. All automation users must be instructed on proper control and use.

#### 17) MAINTENANCE

All maintenance on the controller must be performed with the systems power supply shut off. Check periodically for oil leaks. When topping-up the oil, always use oil of the same type (see data table) and proceed as follows:

- a) Remove the cap "P" (fig.3).
- b) Top-up with oil until it reaches 1.5 mm on the oil cap hole.
- c) Reassemble all of the unit.

**ATTENTION:** The oil of each actuator must be replaced completely every two years. Only use oil of the same type (see data table).

- Check the safety devices of the automation.
- When any operational malfunction is not resolved, disconnect the power supply from the system and request the assistance of qualified personnel.
- If the leaves move jerkily, or if excessive noise is noticed during manoeuvring, this could be due to air being trapped in the hydraulic circuit, and therefore a bleed operation may be required.

##### 17.1) Oil bleed

**NOTE:** The actuator is supplied without air in the hydraulic circuit. If a bleed operation is required, proceed as described below.

- a) Remove the cover from the actuator.
- b) Activate the opening command and loosen the bleed screw (S) for opening (fig.19-20) during leaf movement.
- c) Let the air out until non-emulsified oil appears (if possible, try to prevent the oil leaking out of the bleed screw from falling into the foundation case).
- d) Tighten the bleed screw before the actuator runs out of operation time.
- e) Activate the closing command and loosen the bleed screw for closing (which can be seen in fig.20) during leaf movement.
- f) Let the air out until non-emulsified oil appears.
- g) Tighten the bleed screw before the actuator operation time runs out.
- h) Repeat this operation several times for both bleed screws.
- i) Restore the oil level, checking that it just reaches below cap "O" (fig.19). Top up with IDROLUX oil of the same type.

#### 18) NOISE LEVEL

The aerial noise level produced by the gearmotor under normal operating conditions is constant and does not exceed 70 dB (A).

#### 19) SCRAPPING

Materials must be disposed of in conformity with the current regulations. In case of scrapping, the automation components do not entail any particular risks or danger. In case of recovered materials, these should be sorted out by type (electrical components, copper, aluminium, plastic etc.).

#### 20) DISMANTLING

When the automation system is disassembled to be reassembled on another site, proceed as follows:

- Disconnect the power supply and the entire electrical installation.
- Remove the gearmotor from its fixing base.
- Disassemble the control panel, if separate, and all the installation components.
- In the case where some of the components cannot be removed or are damaged, they must be replaced.

#### 21) MALFUNCTION: CAUSES and REMEDIES

When any operational malfunction is found, and not resolved, disconnect the power supply from the system and request the assistance of qualified personnel (installer). When automation is out of order, activate the manual release to allow opening and closing manoeuvres to be carried out by hand.

##### 21.1) The gate does not open. The motor does not turn.

- 1) Check that the photocells or electric edges are not dirty, or engaged, or

not aligned. Proceed accordingly.

- 2) Check that the electronic equipment is correctly supplied with power. Check the integrity of the fuses.
- 3) Check that the functions are correct by means of the control unit diagnosing leds (see relevant instructions). Identify any causes for faults. If the leds show a persistent start command, check that no radio controls, start buttons or other control devices keep the start contact activated (closed).
- 4) If the control unit does not work, it must be replaced. Should the checks listed above be satisfactory, replace the actuator.

#### 22.2) The gate does not open. The actuator vibrates but there is no movement.

- 1) The manual release was left engaged. Reset motorised operation. Should an electric lock be fitted, check that it opens correctly after the start command.
- 2) Check that the capacitor is connected to the motor drive terminals.
- 3) Check that the motor common (light blue wire) is properly connected.
- 4) Disconnect and reconnect the power supply to the system. The first start command must open. Should the actuator close, reverse the respective drive connections to the actuator.
- 5) Help the leaf to open by hand. If the leaf opens, check if there are any mechanical problems with the leaf or, if necessary, adjust the by-pass valves as described in the relevant item 12. Should the checks listed above be satisfactory, replace the actuator.

#### WARNINGS

**Correct controller operation is only ensured when the data contained in the present manual are observed. The company is not to be held responsible for any damage resulting from failure to observe the installation standards and the instructions contained in the present manual.**

**The descriptions and illustrations contained in the present manual are not binding. The Company reserves the right to make any alterations deemed appropriate for the technical, manufacturing and commercial improvement of the product, while leaving the essential product features unchanged, at any time and without undertaking to update the present publication.**

### TABLE 1

| Mod.    | Block type       | Pump flow rate l/min | Opening angle (degrees) | Max. leaf length (mt) | Max. leaf weight (kg) | Speed (degrees/sec.) |
|---------|------------------|----------------------|-------------------------|-----------------------|-----------------------|----------------------|
| SUB EL  | electric lock    | 0.4 (V0)             | 130°                    | 3.5                   | 8000N (~800 Kg)       | 3,9°                 |
| SUB     | hydraulic blocks | 0.6 (V1)             | 130°                    | 1,8                   | 8000N (~800 Kg)       | 5,4°                 |
| SUB R   | hydraulic blocks | 0.9 (V2)             | 130°                    | 1,8                   | 8000N (~800 Kg)       | 9°                   |
| SUB E   | electric lock    | 0.6 (V1)             | 130°                    | 2,5                   | 8000N (~800 Kg)       | 5,4°                 |
| SUB ER  | electric lock    | 0.9 (V2)             | 130°                    | 2,5                   | 8000N (~800 Kg)       | 9°                   |
| SUB G   | hydraulic blocks | 0.6 (V1)             | 180°                    | 1,8                   | 8000N (~800 Kg)       | 5,4°                 |
| SUB GR  | hydraulic blocks | 0.9 (V2)             | 180°                    | 1,8                   | 8000N (~800 Kg)       | 9°                   |
| SUB GE  | electric lock    | 0.6 (V1)             | 180°                    | 2,5                   | 8000N (~800 Kg)       | 5,4°                 |
| SUB GER | electric lock    | 0.9 (V2)             | 180°                    | 2,5                   | 8000N (~800 Kg)       | 9°                   |

Fig. 1

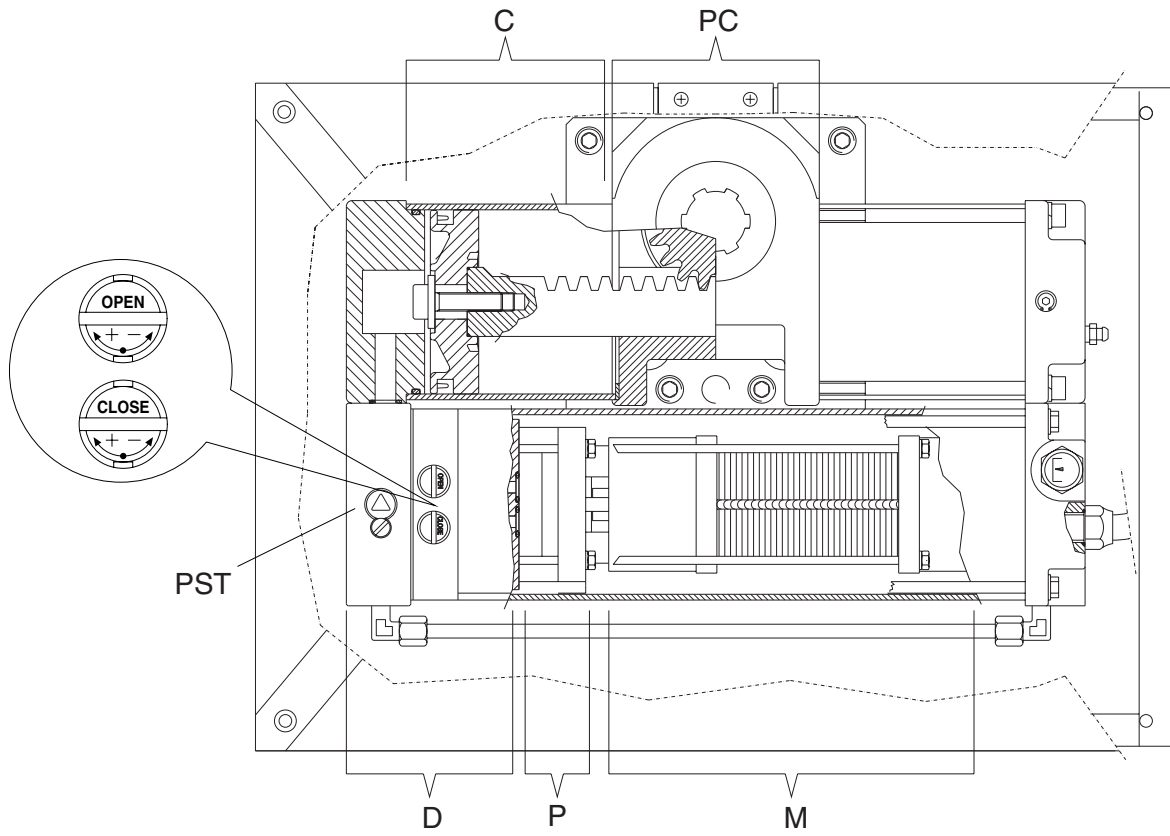

Fig. 2

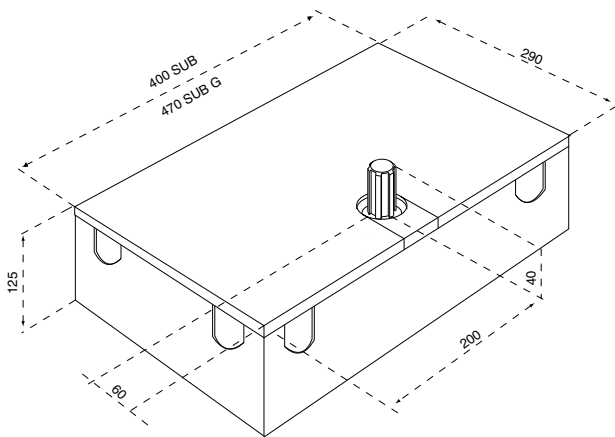

Fig. 3

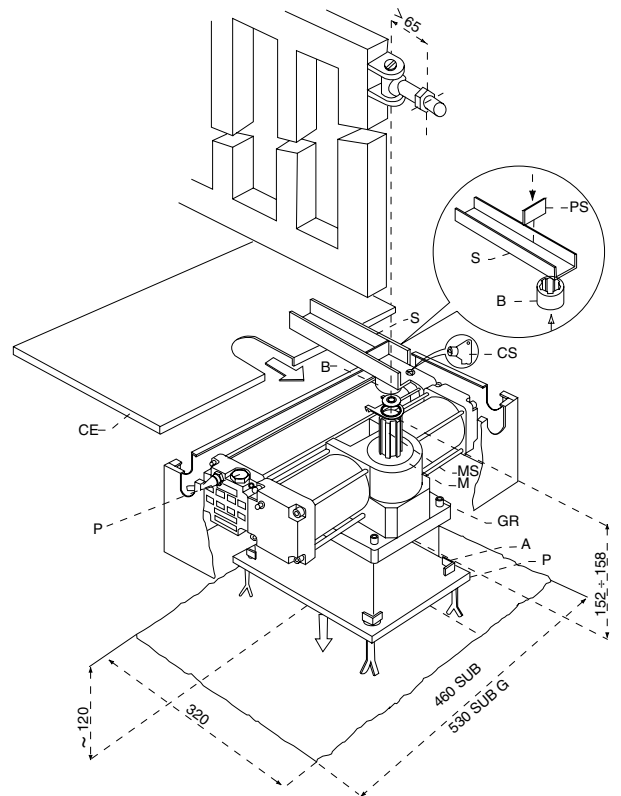

Fig. 4

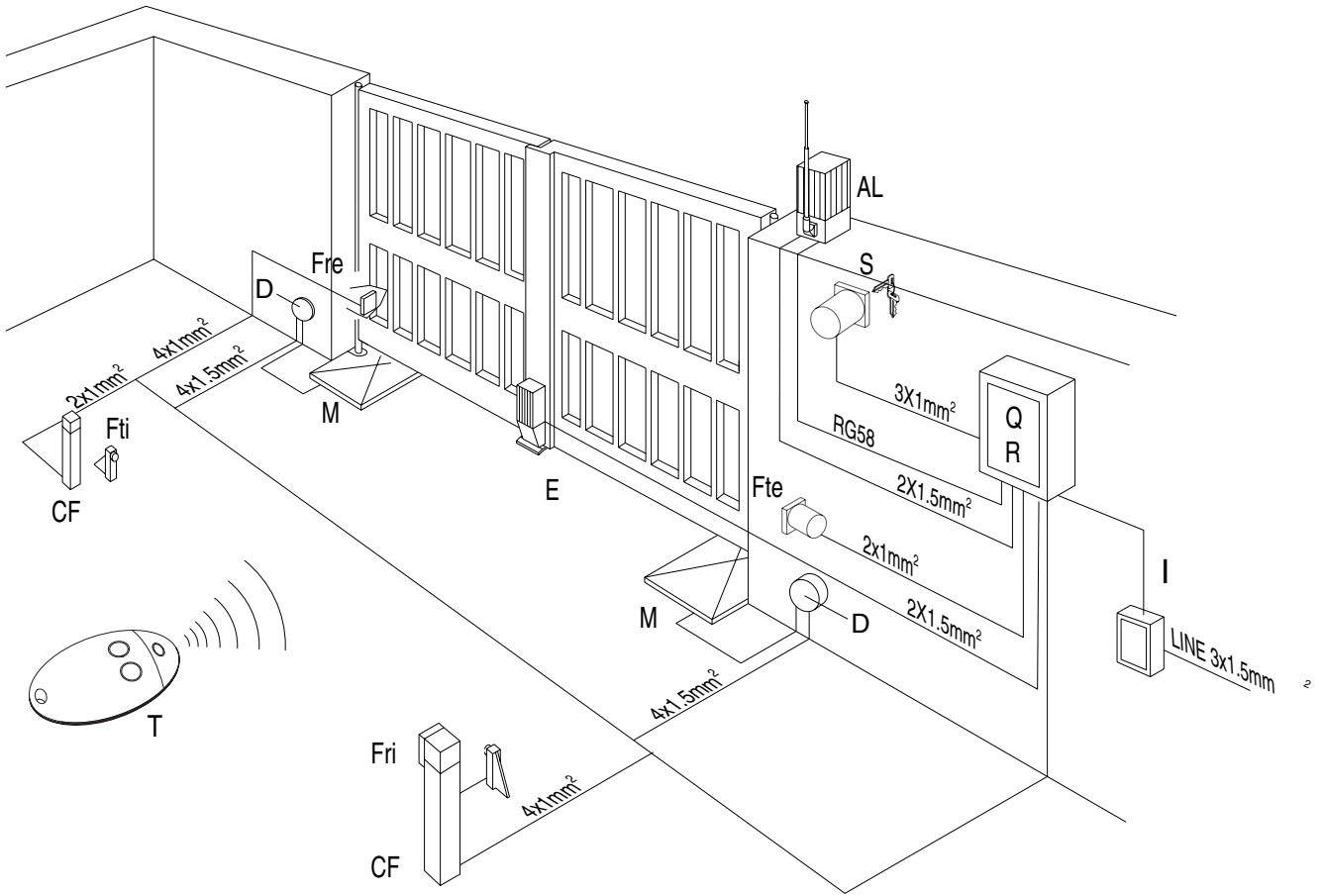

Fig. 5

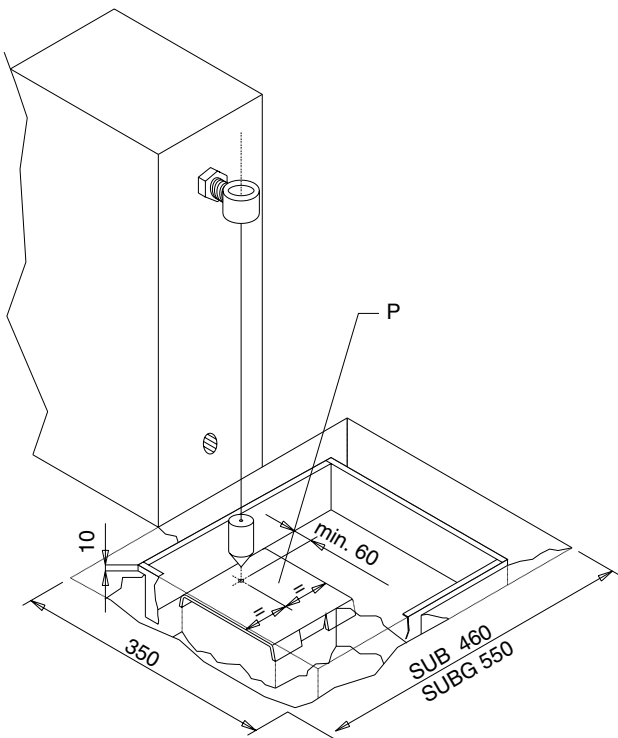

Fig. 6

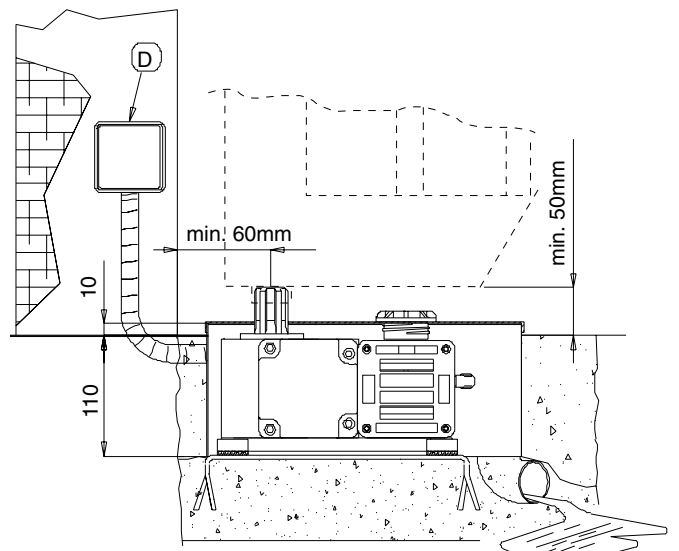

Fig. 7

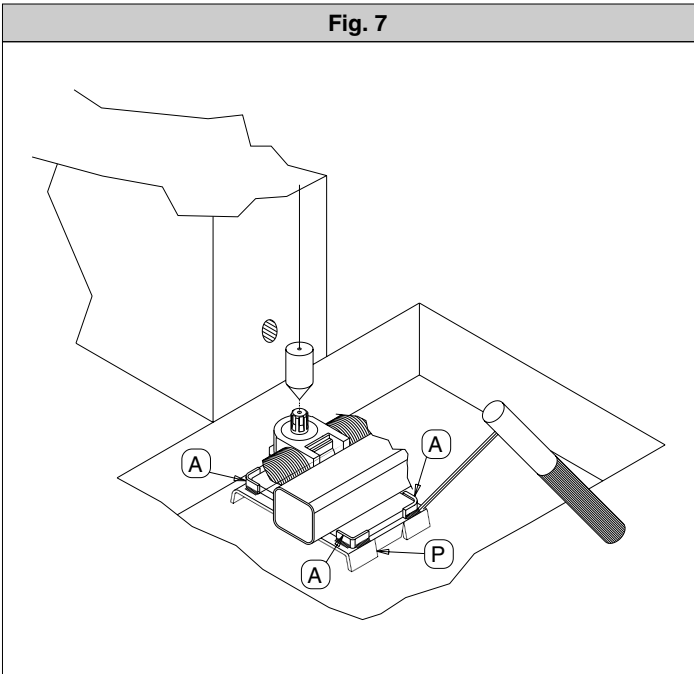

Fig. 8

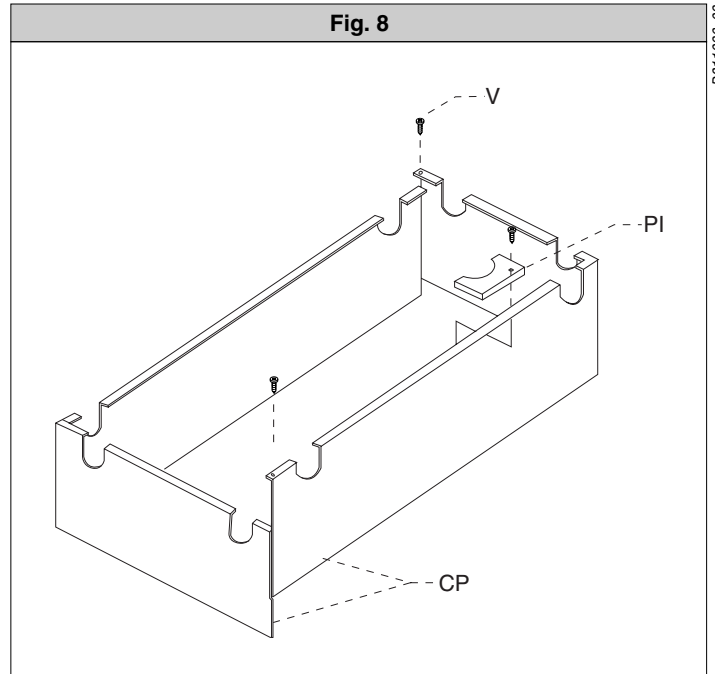

Fig. 9

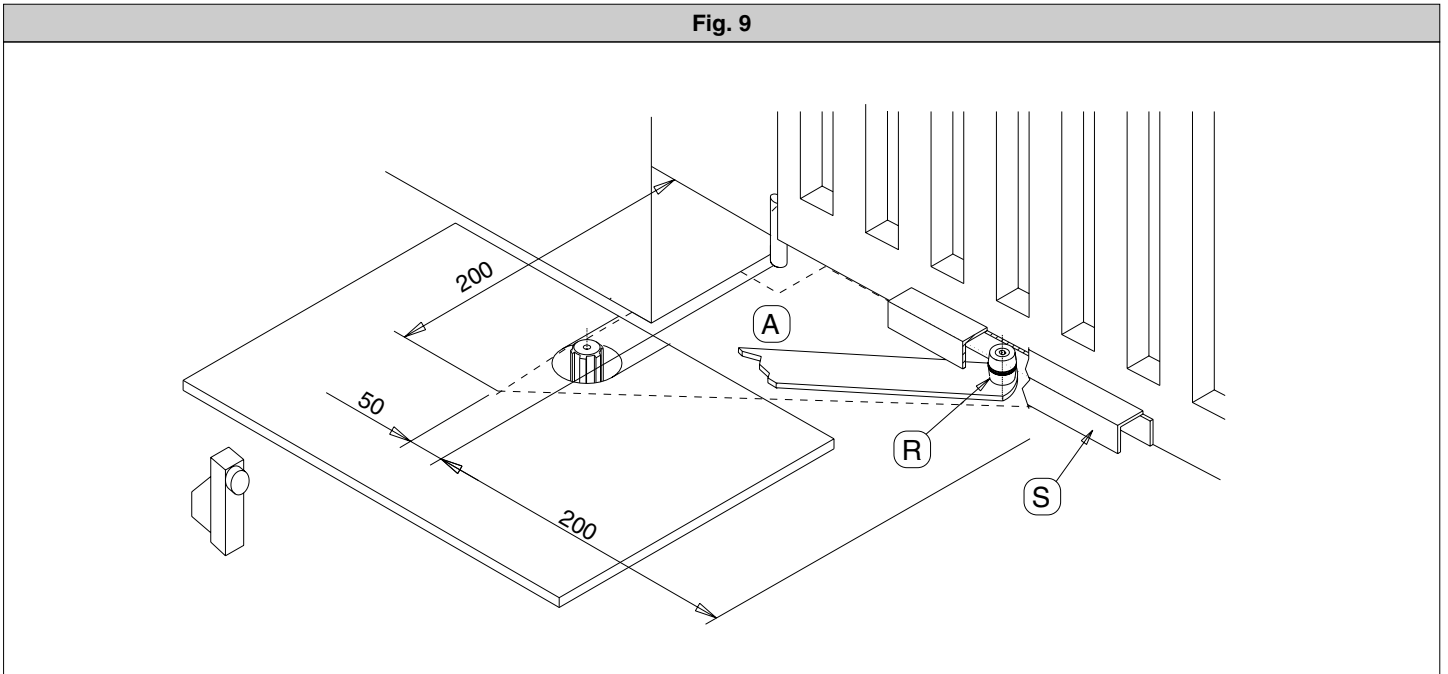

Fig. 10

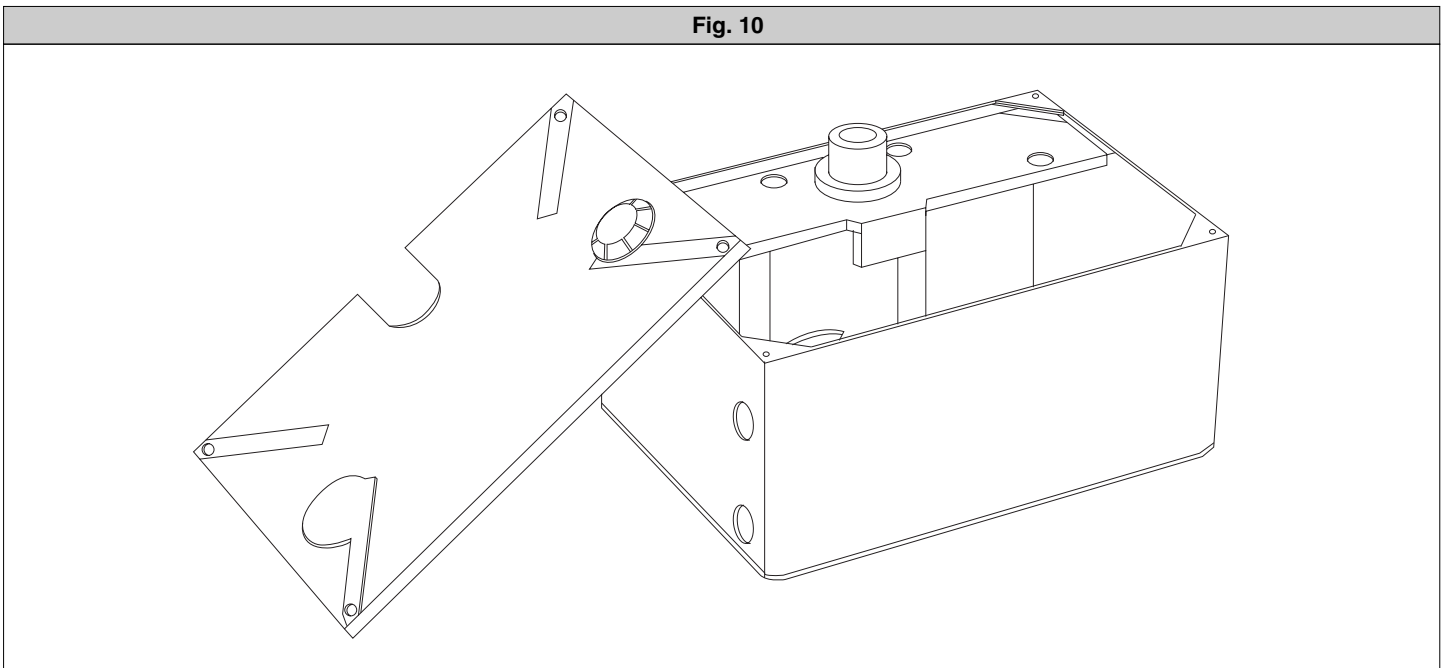

Fig. 11

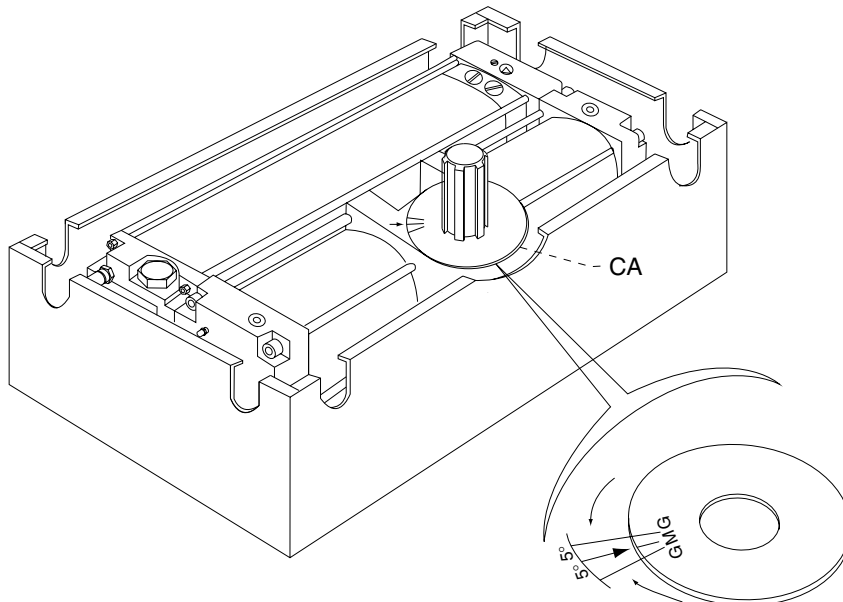
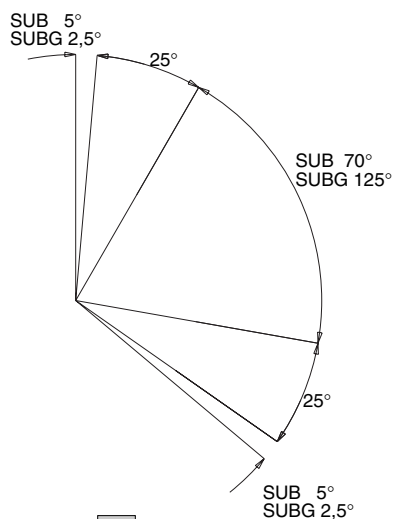
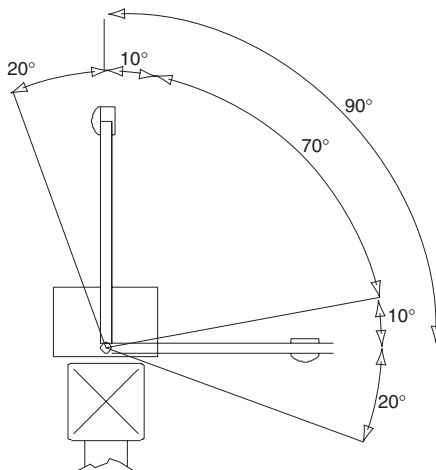

Fig. 12 - 13 - 14



12



13

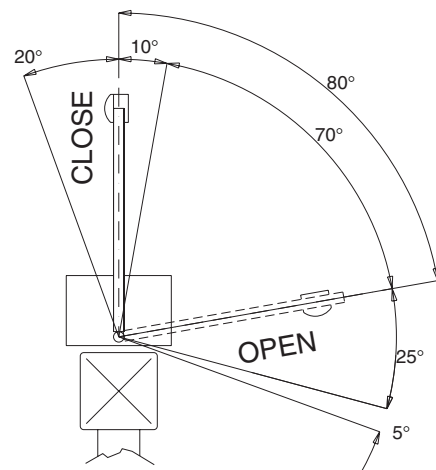

14

Fig. 15

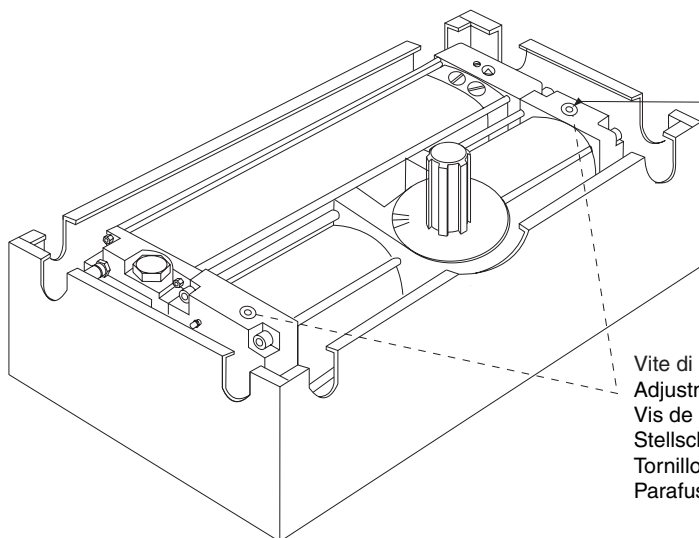

Vite di regolazione  
 Adjustment screw  
 Vis de réglage  
 Stellschraube  
 Tornillo de regulación  
 Parafuso de regulação

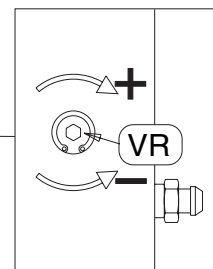

Fig. 16

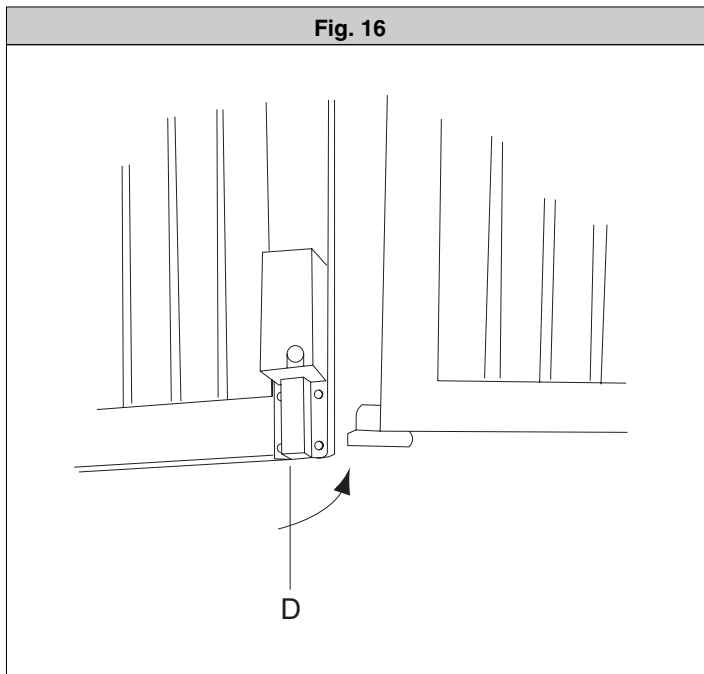

Fig. 17

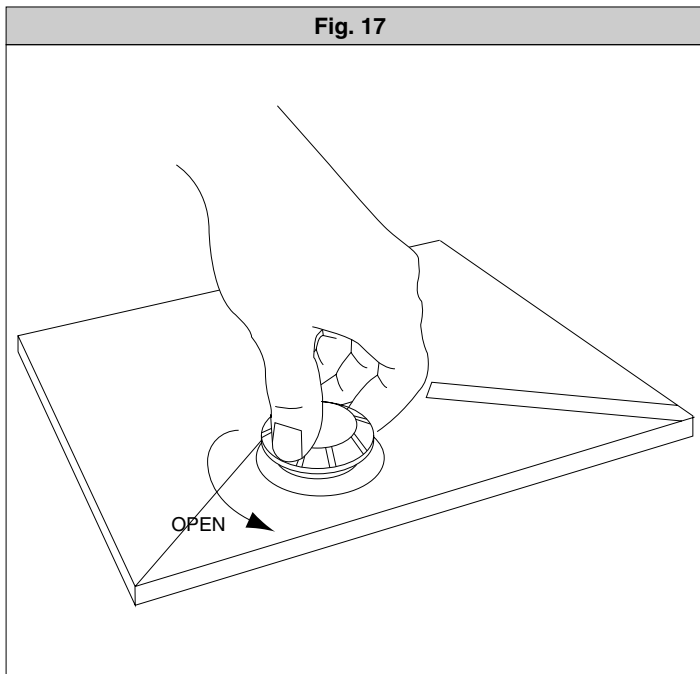

Fig. 18

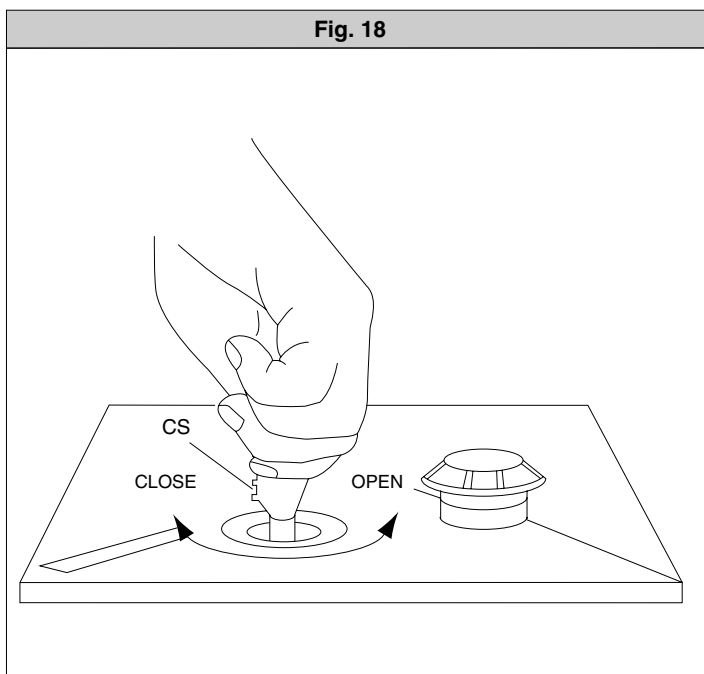

Fig. 19

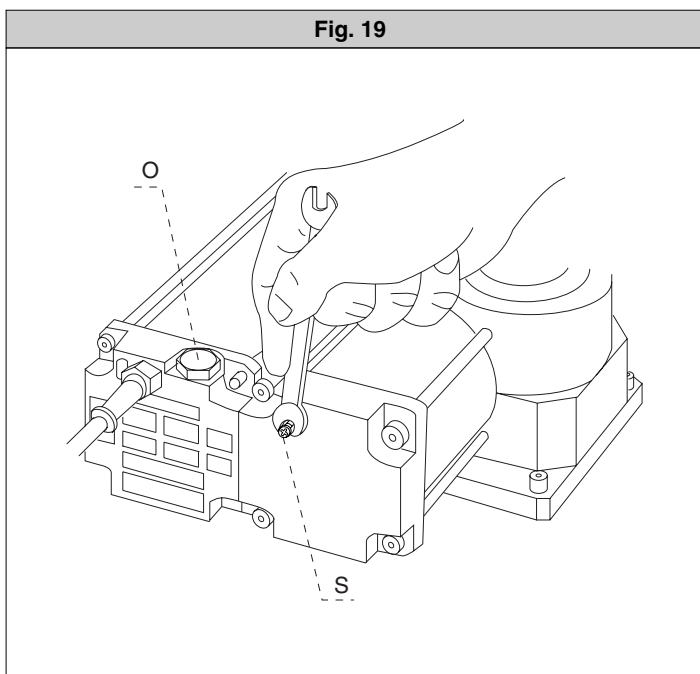
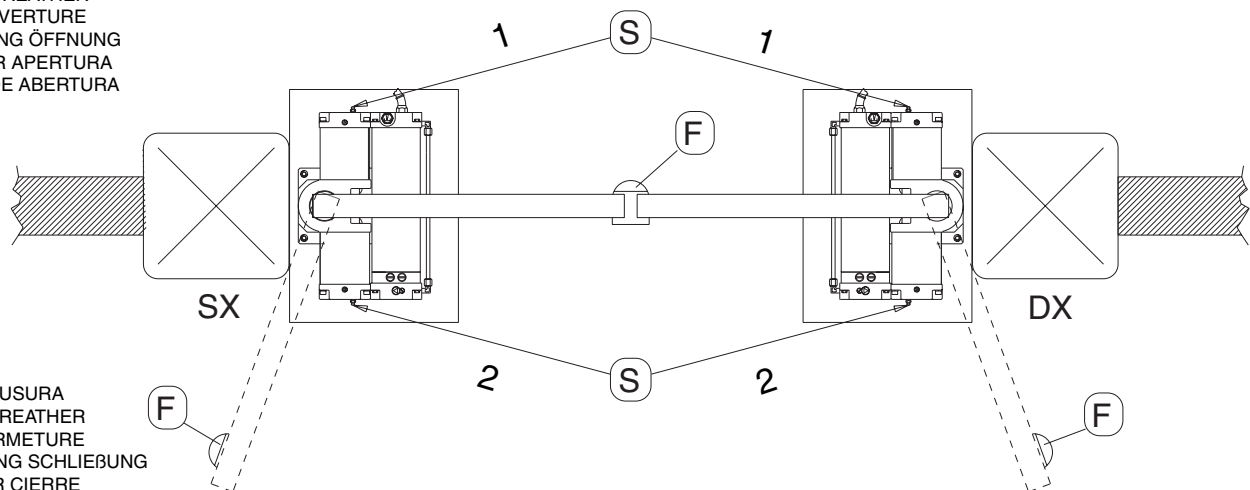

Fig. 20

- 1 • SFIATO APERTURA
- 1 • OPENING BREATHER
- 1 • PURGE OUVERTURE
- 1 • ENTLÜFTUNG ÖFFNUNG
- 1 • PURGADOR APERTURA
- 1 • SANGRIA DE ABERTURA



- 2 • SFIATO CHIUSURA
- 2 • CLOSING BREATHER
- 2 • PURGE FERMETURE
- 2 • ENTLÜFTUNG SCHLIEßUNG
- 2 • PURGADOR CIERRE
- 2 • SANGRIA DE FECHO

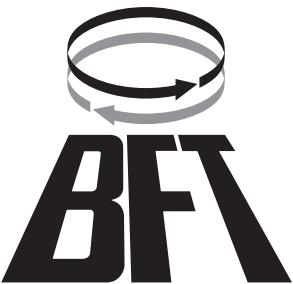

|  |                 |  |               |                      |  |
|--|-----------------|--|---------------|----------------------|--|
| <b>BFT</b>   | <b>FRANCE</b>   | <b>BFT S.p.a.</b>  | <b>ITALIA</b> |                      |  |
| Parc Club des Ayalades<br>35 bd capitaine GEZE<br>13333 MARSEILLE Cedex 14   |                 |  |               |                      |  |
| Tel.   | 0491101860      |  |               | Via Lago di Vico, 44 |  |
| Fax  | 0491101866      |  |               | 36015 Schio (VI)     |  |
| <b>BFT</b>   |                 | <b>DEUTSCHLAND</b>   |               | Tel.naz. 0445 696511 |  |
| BFT Torantriebssysteme GmbH<br>Johannisstr. 14, D-90763 Fürth<br><a href="http://www.bft-torantriebe.de">http://www.bft-torantriebe.de</a> |                 | Tel.int. +39 0445 696533   |               |                      |  |
| Tel.   | 0049 911 773323 | Fax 0445 696522  |               |                      |  |
| Fax  | 0049 911 773324 | Internet: <a href="http://www.bft.it">www.bft.it</a>                                 |               |                      |  |
|  |                 | E-mail: <a href="mailto:sales@bft.it">sales@bft.it</a>                               |               |                      |  |