

BFT Model ICARO

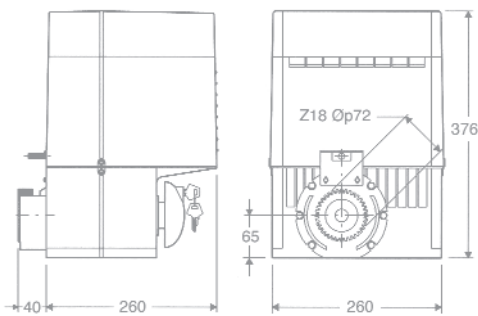

OPERATOR DIMENSIONS



230v Heavy duty sliding gate motor providing continuous duty for gate loads of up to 2000kg.

Commercially rated and suitable for multi-user domestic (apartments) and commercial applications.

The ICARO's many features include:

- Push button programming with LCD display.
- Advanced diagnostic and safety functions.

Huge flexibility and a roomy enclosure for easy cable access.

Self diagnostic controller with parameter auto-set and clear L.E.D. display.

Suitable for:
Continuous duty on multi-user, commercial tracked or cantilever sliding gates.

Integral control panel:
BFT LEO – LCD programmer with auto-set and diagnostics.

Will it fit? Check diagram, shown left.

Toothed drive track (CVZ) available in 1000mm lengths.

Supplied with three bolt, or weld, on adjustable fasteners per length.



2 YEAR WARRANTY



KIT

- ▲ ICARO KIT INCLUDES:**
- 1 × ICARO MOTOR
 - 1 × CONTROL PANEL & RECEIVER
 - 2 × RADIO TRANSMITTERS
 - 1 × ANTENNA
 - 1 × PAIR OF SAFETY BEAMS
 - 4 × MTRS DRIVETRACK & FIXINGS

TECHNICAL SPECIFICATIONS:

ELECTRO-MECHANICAL 230v
COMMERCIAL / CONTINUOUS DUTY
SELF LOCKING
MAX LOAD: 2000kg

ABSORBED POWER: 750w
LEAF SPEED: 9 Mtrs per min – 12 Mtrs per min
(1000 KG) WITH ZS PINION
THERMALLY PROTECTED